



Commercial Buildings – Chilled water systems efficiency

By Jens Nørsgaard, Senior Application Manager, Grundfos, Denmark

Introduction:

Energy use is the single largest operating expense in commercial office buildings, representing approximately one-third of typical operating budget. On an average 30-40% of energy in a commercial building is consumed by HVAC systems. By becoming more energy efficient in HVAC, commercial buildings can reduce operating expenses, increase property asset value, and enhance the comfort of their tenants.

*(<http://www.bluehatmechanical.com/save-on-the-biggest-use-of-power-in-your-building/>)

Purpose:

The purpose of this white paper is to look at chilled water systems design, and to describe ways in which efficient systems can contribute to lower energy consumption and improvements to the environment by reducing pollution and the CO₂ emissions that contribute to global warming.

Table of content

- Background:.....2
- System Efficiency 3
- Chilled water schemes.....3
- Primary pumping system.....3
- Secondary pumping system3
- Chilled Water systems4
- Increased efficiency4
- Traditional solution5
- Primary-secondary.....6
- Primary-secondary-tertiary7
- Variable Primary Flow Systems7
- Design of VPF systems.....8
- Conclusions:.....9

Background:

Modern societies are becoming increasingly urbanised, at the same time as mankind is becoming aware of the global environmental impact our cities are having on the planet. The problems thus created are complex and interconnected.

In developing economies, air conditioning -which was previously seen as a luxury- has now become a necessity due to changing climatic conditions. People have started using air conditioning in their daily lives and expect the same indoor comfort in the places they visit. As we know, air conditioning is normally the most energy intensive application in any establishment, be it a commercial building or an industrial process requirement.

Faced with global warming and dwindling energy resources, the design of energy-efficient air conditioning systems is of prime importance to any designer, as it has a huge bearing on the operating expenses of the building throughout its life cycle. This requires a holistic approach, including building orientation, selection of facade glazing, construction materials, shading, thermal mass, lighting etc. Above all, the air-conditioning system and its components.

An efficient chiller plant has the following characteristics:

- An efficient design concept - Selection of an appropriate design concept that is responsive to changing operating conditions is essential to achieving efficiency. Variable flow pumping systems for large campus applications,

and selecting the quantity, type and configuration of chillers based upon the expected load profile are other factors that influence efficient design.

- Efficient components - Chillers, pumps, fans and motors should all be selected for their stand-alone as well as systemic efficiency. Also consider premium efficiency motors, pumps with high efficiency at the designed operating condition, chillers that are efficient at both full and partial loads.
- Proper installation, commissioning and operation - A chiller plant that meets these first two criteria can still waste a lot of energy and provide poor comfort to building occupants, if it is not installed or operated properly.

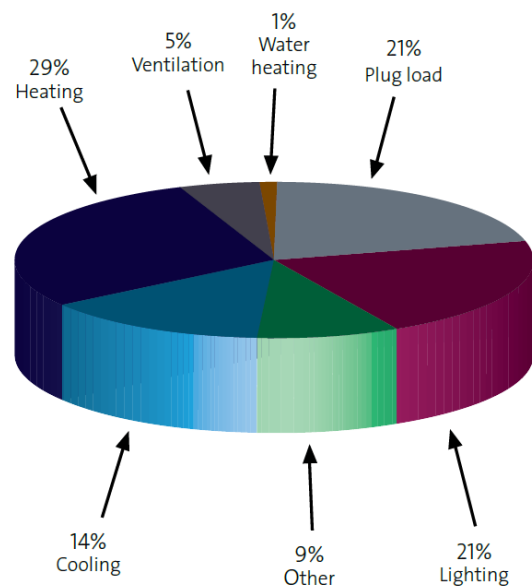

Energy consumption break down in a typical commercial building

System Efficiency

In common with all types of pumping applications, system efficiency for HVAC systems such as air cooling in commercial buildings depends on balancing the piped network with the other components.

While chillers and cooling towers are large contributors to chilled water performance, a primary player in determining how well a plant performs is the efficiency of the chilled water distribution system. To appreciate the various hydraulic considerations associated with planning chilled water and how they influence system performance, it is important to understand how technology and design challenges over the years have influenced today's approach to chilled water pumping.

Basically, each piping scheme in air conditioning application is classified according to its use. One is meant for distribution of chilled water from the chiller plant to the conditioned space. While the other is to dissipate the heat from the chiller into the atmosphere through cooling towers. i.e., condenser water pumping schemes.

In this white paper, we shall discuss in brief the various schemes generally employed in commercial buildings HVAC system.

Chilled water schemes

A chilled water pumping scheme is one by which chilled water is circulated throughout the building or through cooling coils in air handling units (AHU) to provide space cooling. It basically consists of production and distribution loops. Production loop takes care of chilled water production in the plant which consists of chillers, primary chilled water pumps, control valves and accessories. The distribution loop takes care of pumping water to the changing demands of the space through a network of pipes, valves and cooling coils.

Primary pumping system

The main objective of the primary pump is to circulate chilled water within the production loop. This pump is typically located anywhere

(either upstream or downstream of the chiller), provided the pump satisfies the following conditions:

- Maintains the minimum dynamic pressure head (inlet pressure) at the heat exchangers (evaporator coil) at the chiller. If the recommended inlet pressure is not high enough at these components, proper flow will not be established through them
- Accommodates the total pressure (static plus dynamic head) on system components such as chiller's evaporator, valves etc.,
- Meets the minimum net positive suction head requirements. That is the system inlet pressure at the pump must be positive and high enough for the pump to operate properly.



Grundfos TPD twin pumps used in a medium size chilled water plant

Secondary pumping system

Here the main objective is to distribute the chilled water to the various cooling coils overcoming the frictional resistance offered by the pipes, valves and bends in the entire network. The distribution system may contain other components such as expansion tanks, control valves, balancing valves, check valves, air separators etc.

These pumps are usually configured in headered fashion, for system redundancy.

Chilled Water systems

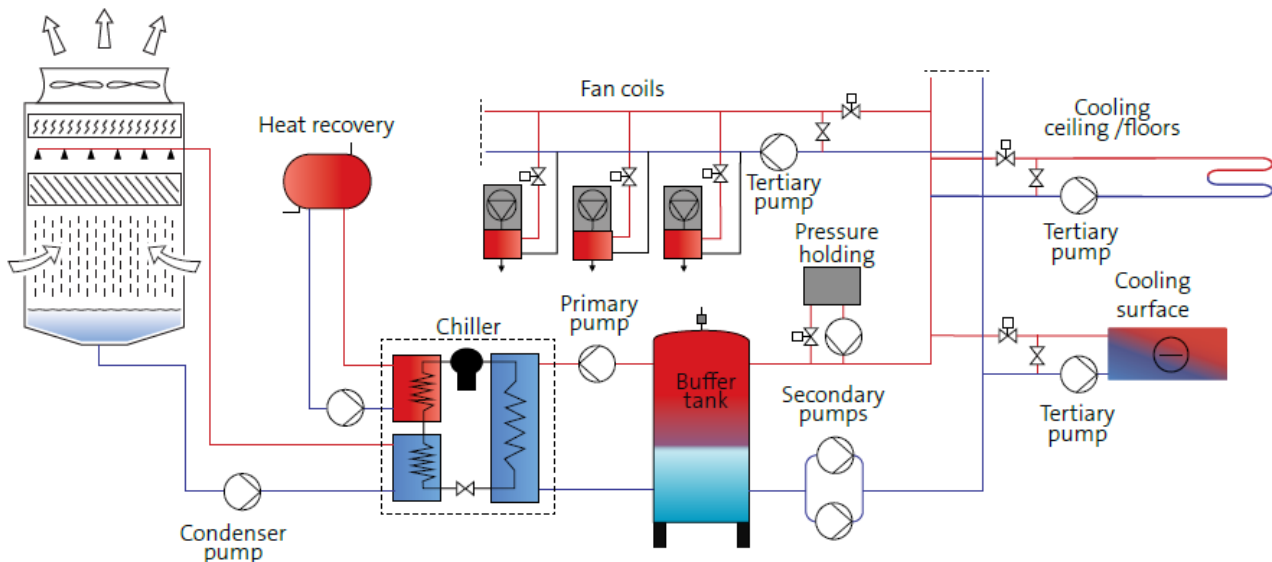

Schematic of a primary / secondary / tertiary chilled water system

A central chilled water system (shown above) generally consists of the following five sub-systems as individual heat-transferring loops of circulating water:

- Refrigeration loop - Consists of a chiller in which a refrigerant changes its state at various stages to either absorb or reject heat from the evaporator and condenser respectively.
- Heat rejection loop - Consists of cooling towers, condenser water pumps and water treatment systems. This loop is used to reject the heat from the hot refrigerant into the atmosphere either through radiators (in the case of air cooled systems) or through cooling towers wherein water removes heat from the condenser coil and ejects it to the atmosphere.
- Chilled water loop - Consists of circulation pumps, which carry the chilled water from the chiller to the various distribution systems like Fan Coil Units (FCU) or Ceiling Suspended Units (CSU) or Air Handling Units (AHU) or Radiant Cooling Panels (RCP)
- Air side loop - Consists of a low side (air side) distribution network like Fan Coil Units (FCU) or Ceiling Suspended Units (CSU) or Air Handling Units (AHU). Centrifugal fans are used in AHUs which are VFD (Variable Frequency Drive) driven based temperature requirement of conditioned space.

- Controls loop - Integrates the complete system to ensure that it works as intended. All the sub systems: Chillers, pumps, cooling towers, fan coil units, cooling tower fans and water treatment systems are all integrated into a single system for easy monitoring and control.

Increased efficiency

Possibilities for optimizing the energy consumption of a central air conditioning plant lie mainly with chillers, fans and pumps in the order of their contribution. Modern chillers from renowned chiller manufacturers have evolved over the years and offer sophisticated designs, delivering better energy performance over their previous designs.

Variable speed chillers utilize more efficient operation by offering more adaptable chillers where compressor speed is varied relative to plant load. In 1998, for example, minimum full load efficiency (COP) for a 1800 kW centrifugal chiller was around 4.7, whereas building owners today are aiming towards a COP of 6.4 for the whole plant (including pumps, fans and ancillaries).

There are a great many details associated with designing an efficient chiller plant; however, the following are some of the most essential ones to be considered:

- Focus on chiller part load efficiency: Peak loads in most commercial buildings are a rarity, and it is imperative to look for chillers which offer the best part load efficiency.
- Design efficient pumping systems: Design of variable volume pumping systems by incorporating variable speed drives on the pumps can result in significant savings in the operating costs of the plant. Chiller plants which allow varying flow through chillers use less space, fewer components and reduce pumping energy to nearly 40%, compared to the conventional constant flow approach.
- Proper selection of cooling tower: Proper sizing and control of cooling towers is essential to efficient chiller operation. A tower may be rated to cool 800 m³/h of

water from 35 °C to 30 °C when the ambient wet bulb temperature is 26 °C. Assumption of wet bulb conditions can lead to improper sizing of a cooling tower.

- Integrated chiller controls: Modern chillers provide a wealth of detailed operating data which can be used to make decisions about how to operate the rest of the system.
- Commission the system: Commissioning a HVAC system, (i.e., functionally testing it under all anticipated operating conditions to ensure the system performs as intended) is also vital as it establishes a reliable basis for measuring performance and any improvements in system efficiency and reliability.

Traditional solution

Traditionally, chilled water is delivered through a simple direct-primary, constant flow pumping scheme. Here, chilled water is pumped at a constant flow rate which is independent of the cooling load. During part load conditions, which occurs most of the time, three way control valves at cooling coils are used to bypass the chilled water back to the return line. Chilled water mixes with return water from the cooling coils and this results in lower chilled water return temperature to plant. This lower return water temperature reduces the temperature differential (ΔT) across the chillers.

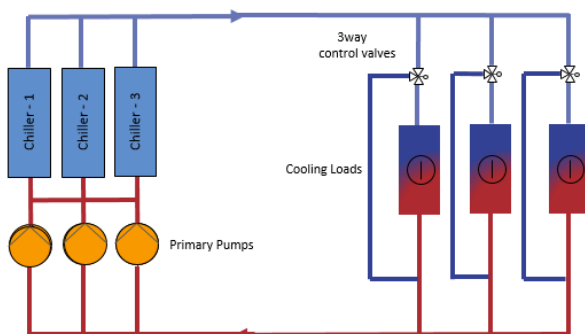

Constant flow primary pumping system

This method of chilled water pumping results in a significant waste of energy and a loss of

performance of the main chiller plant caused by low ΔT .

Note that chillers will control only the leaving temperature from evaporator coil, whereas it is the cooling coil's performance which will influence the temperature of the chilled water returning to the plant room, and this has a large bearing on the ΔT of the plant.

Implications of low ΔT , example:

The designed performance of a chilled water system is 1.5 MW at a design ΔT of 6 °C. If the system is suffering from low ΔT syndrome, the cooling capacity will be reduced.

If the real ΔT is only 2 °C, the systems cooling capacity is reduced with two thirds. The performance of the system is now only 0.5 MW.

Primary-secondary

A primary-secondary pumping scheme divides the chilled water system into two distinct circuits that are hydraulically separated by a de-coupler (neutral bridge). In primary/secondary systems, chilled water flows through the chiller primary loop at a constant flow rate, whereas in secondary loop, flow rate is varied according to the load. The hydraulic independence of each loop prevents variable flow in the secondary loop from influencing the constant flow in the primary loop.



Secondary pumps in a large stadium chilled water plant

The speeds of the secondary pumps are determined by the controller measuring differential pressure (DP) across the supply and return mains of the chilled water loop or across the most critical load in the pipe network. Primary – secondary variable flow systems are more efficient than constant flow systems, because unnecessary pumping is avoided in the distribution loop, resulting in better energy efficiency.

During part-load conditions, the two way valves begin to close, causing an increase in system differential pressure which is detected by a DP (differential pressure) sensor. Subsequently the secondary pump control panel reduces the pump speed and flow of the secondary pump to match the load requirement.

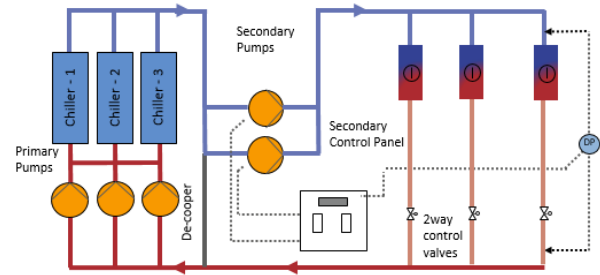

Primary-secondary pumping system

The decrease in flow from the secondary loop means the chilled water will flow from the supply side to the return side to maintain the constant volume through the chillers. This happens since the production loop (primary side) flow is greater than the distribution loop (secondary side) flow. Similarly, when the load increases at the space area, zone temperature increases which makes the 2 way valves to open more. This reduces differential pressure across the cooling loads, causing the secondary chilled water pumps to ramp up.

In these changing load patterns a hydraulic de-coupler located between the suction headers of the secondary and primary pumps acts as a balancing line which allows chilled water to flow in either direction (from supply to return and vice versa). Without this de-coupler line, both the primary and secondary pumps would be in series, making the system unbalanced and causing operational problems.

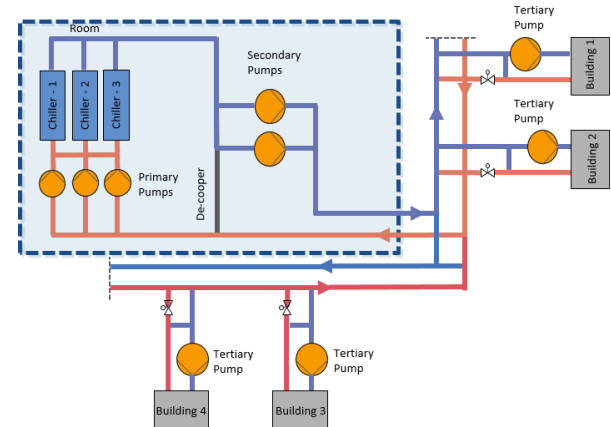

Primary-secondary-tertiary pumping system

Primary-secondary-tertiary

When the buildings to be served are distributed over a larger area, such as a university campus, so-called “primary-secondary-tertiary” schemes help to reduce the pump pressures in the system. By splitting the system head between the secondary and tertiary pumps, excessive pressurization in zones which do not need high pressure is reduced.

In these systems, all cooling coils or building loops may be served by a third set of pumps – tertiary pumps.

These distributed pumping systems are well suited for large, multiple zone buildings or multiple building systems with central energy plants. These systems are actually a collection of smaller systems operating independently of each other, but all of them using the same distribution piping and the central chiller plant.

Tertiary pumps are sized for requirements of the specific cooling coil alone. Pump head is also calculated only to overcome the frictional loss in the tertiary loop.

Variable Primary Flow Systems

Recall that the primary loop relies on maintaining a constant flow through the chiller. This is a challenge to engineers who are conscious of the need to make energy savings. It would make sense to employ modern pumps with variable frequency drives which could provide the following benefits:

- Low energy cost due to variable flow (Chilled water is pumped only to the requirement of the load).
- Reduced operating cost.

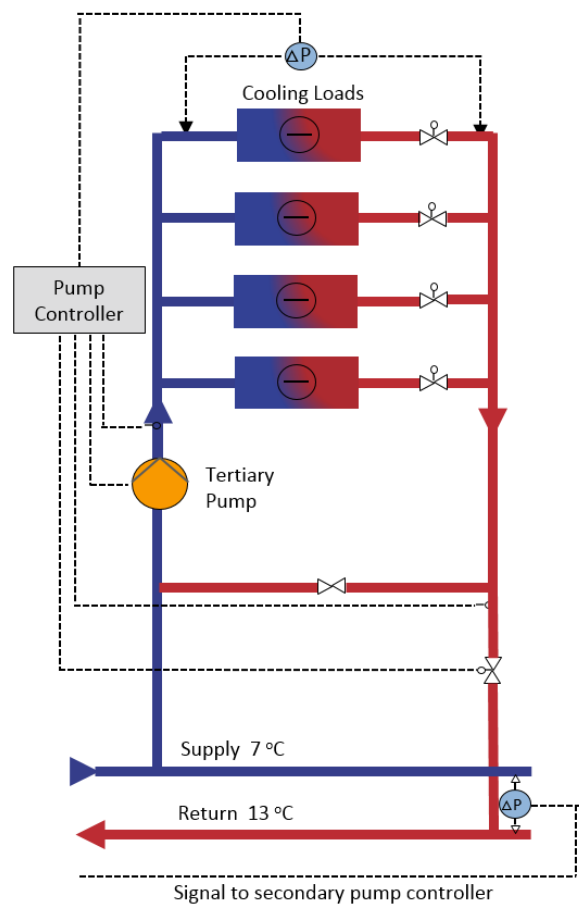

Tertiary pumping system

Each of the tertiary pumps has its own pump controller, responding quickly to any changes in loop pressure caused by fluctuating demand. These pumps are usually speed-controlled and when used as part of a suitable building connection strategy, they work in coordination with speed-controlled central plant distribution (secondary) pumps.

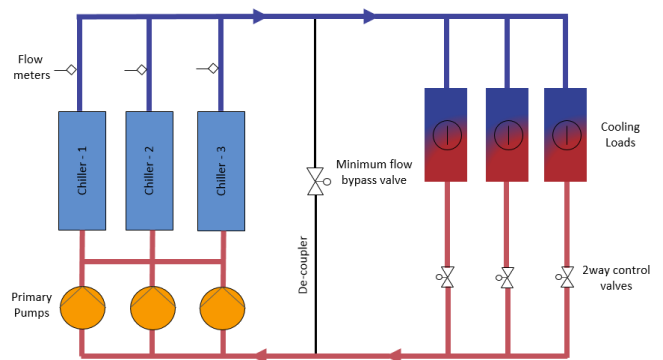

Variable primary flow system

- Better ability to tolerate below design chilled water temperature differentials.
- Less capital cost, since secondary pumps and its accessories are eliminated altogether.

With the advent of more sophisticated control systems and improvements in chiller technology over the past few decades, variable primary flow (VPF) systems are widely used in the air conditioning industry. It provides immediate cost savings, as it eliminates secondary distribution pumps, associated pipes and accessories from the circuit.

Here the primary pump is sized for circulating chilled water through the chiller evaporator coil and further to the cooling coil loads

Design of VPF systems

There are certain limitations within which variable primary flow systems should be designed:

- In order to reduce the risk for freezing, chiller manufacturers recommend a safe minimum evaporator flow beyond which flow should not be reduced
- Velocity of flow through evaporator to be maintained between 1 and 3 m/s contain tube erosion.
- Rate of change of flow through the chiller should be as described by the respective chiller manufacturer
- Chillers in parallel configuration are to be of equal capacity
- System should be tolerant on temperature variations

Evaporator flow and velocity limitations

Every chiller manufacturer recommends the minimum flow range which can be pumped through the evaporator coil. Turn down ratio depends on chiller type also. Normally the minimum evaporator coil flow is 40 to 60% of the design flow.

Any operation of the chiller less than the safe minimum flow will result in ice formation in the evaporator potentially damaging the equipment.

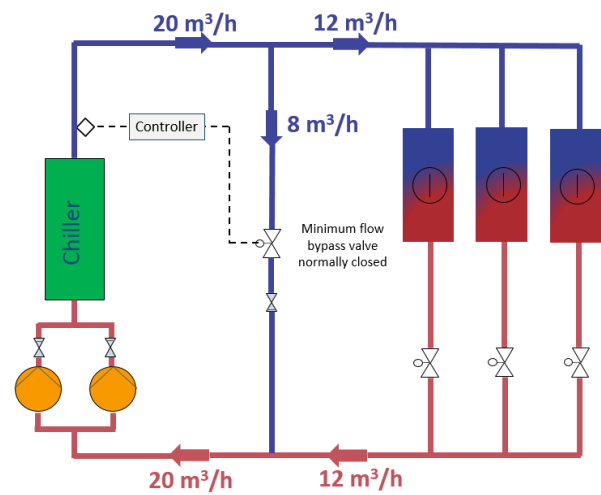

Variable primary flow system with bypass valve

Minimum flow bypass valve

In VPF systems, a bypass valve may be fitted in the common line. It is via a controller connected to a flow meter in the water loop. When the chilled water flow is above the evaporator's safe minimum flow, the valve is normally closed. If the cooling load requirement decrease to a level where the flow is less than the evaporator safe minimum flow, excess pumping is taking place in the chiller plant.

In such a scenario, the amount of flow that is in excess to the cooling load requirement needs to be bypassed back to the chiller plant. Only in such instances, bypass valve opens up proportionately to divert the volume of chilled water back to the chiller plant.

An example, say if the cooling coils need only 12 m³/h whereas the minimum safe recommended evaporator coil flow in the active chiller itself is 20 m³/h, the excess 8 m³/h is diverted through bypass line.

Selection of bypass valve

Selecting an appropriate valve actuator is critical to ensure the proper functioning of the bypass function. One which maintains a linear relationship between the valve position and flow rate will do.

Can bypass valves be avoided?

Bypass valves in VPF systems may be avoided when:

- The building load is constant
- The building load is never is never below the evaporator safe minimum flow, which is typically 40 to 60 % of the nominal load.

- A by-pass pump is substituting the bypass valve.

The solution with a Grundfos TPE2 pump as the by-pass pump:

A Grundfos TPE2 pump can be used to maintain a minimum water flow rate. The pump is controlled in constant ΔP mode ensuring that a constant pressure and hence flow is maintained over the chiller evaporator.

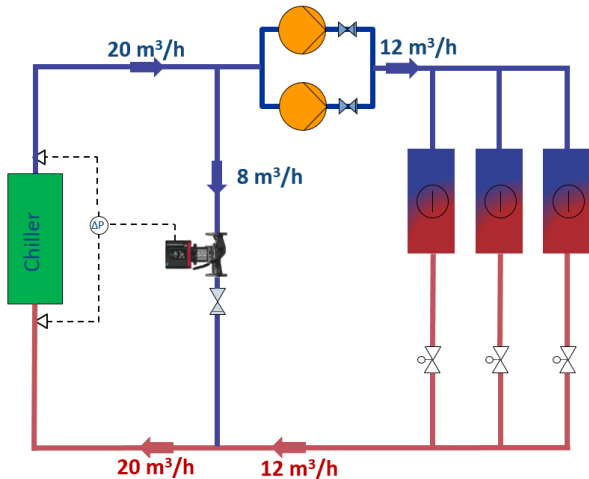

Variable primary flow system with bypass pump

When the flow through the chiller is well above the minimum flow, the pump is stopped.

Introducing a bypass pump in a variable primary flow system will substitute a bypass valve, a controller and flow meter. The pump is self-controlled and does not require any additional controller or flow meter. Hence, in most cases there will be an initial cost, commissioning and maintenance saving connected to this installation.

Set-up a TPE2 pump for this application is discussed further in the one-pager "Chilled water. By-pass pump control" and related commissioning paper.

Conclusions:

Chilling water systems are a key part of HVAC solutions for commercial buildings, and their installation and continuous operation represent quite a significant operating expense. A variety of suitable system designs, each tailored to fit specific building layouts and load requirements can provide efficient, comfortable living conditions at the lowest possible price.

Variable primary flow systems are the one of the simplest piping schemes, none the less it is a very efficient one because the risk of excess pumping is eliminated. This may be achieved either by installing a bypass pump or valve. However, installing a bypass pump will in most cases lead to a lower system life time cost.

be think innovate

GRUNDFOS Holding A/S
Poul Due Jensens Vej 7
DK-8850 Bjerringbro
Tel: +45 87 50 14 00
www.grundfos.com



The name Grundfos, the Grundfos logo, and be think innovate are registered trademarks owned by Grundfos Holding A/S or Grundfos A/S, Denmark. All rights reserved worldwide.